



# HR2510

## 10 Meter Amateur Mobile Transceiver

# Contents

Welcome .....	2
Controls and Functions .....	3, 4, 5
Front Panel Connector .....	6
Rear Panel Connectors .....	7, 8
Installation .....	9
Operation .....	10, 11, 12, 13, 14
Specifications .....	15
Troubleshooting .....	16
Amateur Radio Operation .....	17, 18

# Welcome !

To the world of 10 Meter amateur radio communications! You have purchased what we feel to be the finest 10 Meter mobile transceiver available. Your HR 2510 has been designed using the latest state of the art electronics to give you years of trouble free service. To get the most from your HR 2510, please read this operating guide thoroughly.

***WARNING: To operate this transceiver, you MUST have an FCC Radio Amateur Operator's license. Operation of this device without a license is ILLEGAL and carries heavy penalties.***

## Unpacking

Your HR 2510 is supplied with the following items. If any items are missing or appear damaged, DO NOT return the unit to the place of purchase. Instead, contact Uniden Customer Service at (317) 842-2483, 8 am-5 pm EST, Monday through Friday.

- HR 2510 10 Meter Transceiver
- Dynamic Microphone with Channel Up/Down control
- Transceiver & Microphone Mounting Brackets & Hardware
- Power Cord with In-Line fuse holder
- Accessory Plug (Jumpered for internal speaker use)
- Accessory Plug (With wires for connecting accessories)
- This operating guide
- Registration Card (Remove from operating guide, fill out, and mail)

We also recommend that you retain the original box and packing, as it makes a convenient way to transport the unit.

# Controls and Functions

- 1. Mode Switch** - This control is used to select the desired transmit mode. The modes available are: CW, LSB, USB, AM, and FM.
- 2. SWR/CAL Control** - This control is used to adjust the calibration of the SWR meter while in SWR CAL mode.
- 3. RIT Control** - The Receiver Incremental Tuning control is used to fine tune the received signal. This is used in USB and LSB modes to obtain maximum clarity of reception, and in CW mode to control the pitch of the beat note. The RIT control can tune the receive frequency about  $\pm 3$  KHz. This control will not affect the transmit frequency, or the frequency display, but will change the receive frequency.
- 4. RF Gain Control** - This is used to vary the RF input to the receiver. This control is used to help eliminate strong, adjacent signals.
- 5. Mic Gain Switch** - Pressing this switch activates the built-in microphone attenuator. This feature is designed to be used when operating the HR 2510 in high ambient noise environments.
- 6. TX Switch** - The TX switch is used to lock the transmitter on for tuning purposes, except in CW mode. In CW mode the external key must be locked down. The microphone is disconnected unless the PTT switch is also depressed.
- 7. Meter Switch** - This switch is used to select the operating mode for the multi-function meter. The meter modes are: S/RF, Modulation, SWR Calibration setting, and SWR. Each time the Meter switch is pushed, the next mode is selected. See the operation section for more information on meter usage. The currently selected mode is displayed above the meter.
- 8. PA Switch** - Pressing this switch enables the PA Mode, if an external PA speaker is installed. When in PA mode, the normal transmit functions of the radio are disabled, but the receive audio is routed through the PA speaker.
- 9. NB Switch** - Pressing this switch enables the built in noise blanker. The noise blanker in your HR 2510 is very effective in eliminating interference generated by vehicle ignition systems.

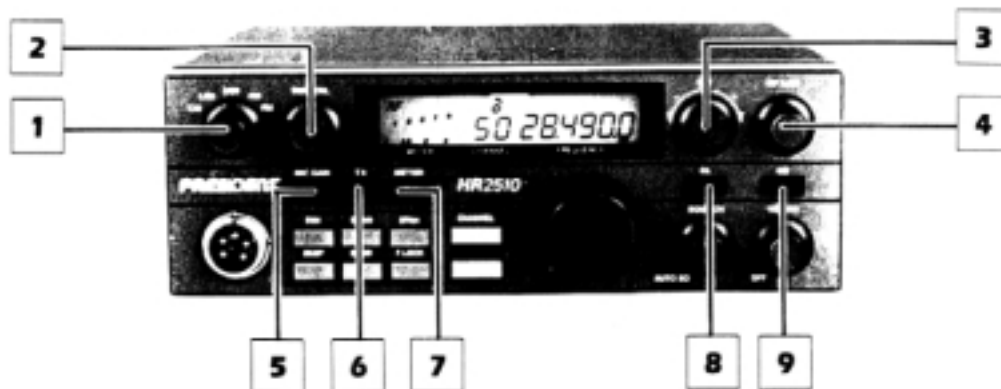

## Controls and Functions - continued

10. **Dim Switch** - Pressing the Dim switch dims the display backlighting. Press again to return backlighting to its normal (high) level.
11. **Scan Switch** - The Scan control is used to scan up to 50 channels in each band segment. See the section on operation for more information on using the Scan Control.
12. **Span Switch** - This control is used to select either 10 KHz, 1 KHz, or 100 Hz steps for the VFO. The currently selected step is indicated by a line under the relevant digit on the Frequency Display
13. **Channel  $\wedge$  and  $\vee$**  - Pressing these controls will step up or down to the next 10KHz channel in the currently selected band segment. The currently selected channel is displayed next to the frequency display.
14. **Band Switch** - Pressing this control will select one of the four band segments. Band segments are: **a**:28.0000 - 28.4999, **b**:28.5000-28.9999, **c**:29.0000-29.4999, and **d**:29.5000-29.6999 MHz. The currently selected band segment is displayed above the channel display.
15. **F. Lock Switch** - Pressing the Frequency Lock button will disable all frequency determining controls on the front panel, to prevent accidental changes of frequency.
16. **VFO Control** - The Variable Frequency Oscillator control is used to select the desired transmit and receive frequency. Tuning is continuous throughout the entire range of the HR 2510, with no need to select band segments.
17. **Squelch Control** - The Squelch control is used to adjust the squelch function, which eliminates the "rushing" sound between transmissions. Turning the squelch control CCW until it clicks enables the auto squelch, eliminating the need to manually adjust the squelch.
18. **On/Off/Volume Control** - This control is used to turn the unit on or off and to adjust the volume.
19. **Beep Switch** - Pressing this control will cause a short beep tone to be transmitted whenever you release the PTT switch on the microphone.

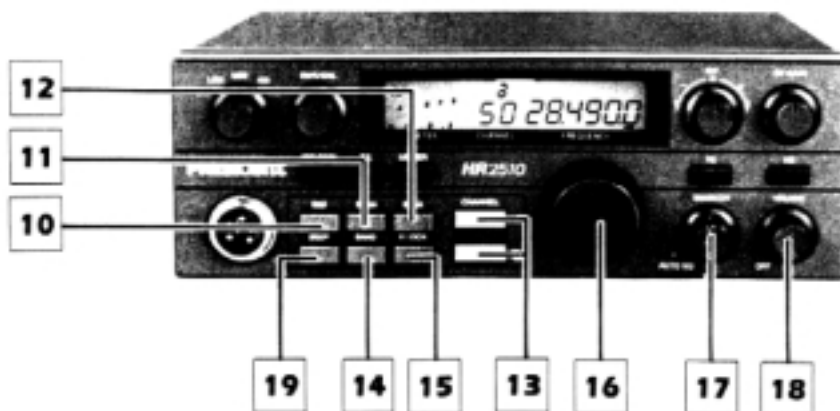

## Controls and Functions - continued

- 20. **Multifunction Meter** - This meter can display S/RF, Modulation, SWR Cal, or SWR. See item (7), Meter Switch and the operation section for more information
- 21. **Frequency Display** - The Frequency Display displays the currently selected transmit and receive frequency.
- 22. **Meter Mode Display** - Displays the currently selected meter operating mode.
- 23. **Band Segment Display** - Shows the currently selected band segment.
- 24. **Channel Display** - Gives the selected channel number.
- 25. **TX Indicator** - Illuminates when PTT or TX Switch is pressed, or CW key is down.
- 26. **VFO Step Indicator** - Displays the currently selected VFO step. (The photo shows 100Hz step selected).

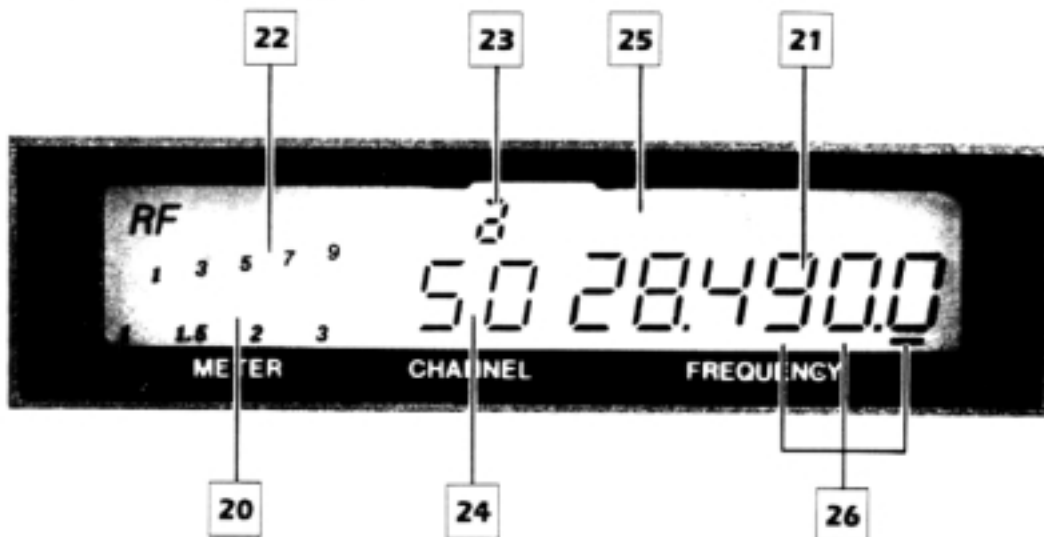

- 27. **Remote Control Channel  $\wedge$  and  $\vee$  switches** - You can step up or down by one 10 KHz channel within the current band segment using these controls. See the section on operation for more information.
- 28. **PTT Switch** - The Push to Talk switch is used to control the transmit and receive of your HR 2510. Press to transmit, and release to receive.



# Front Panel Connector

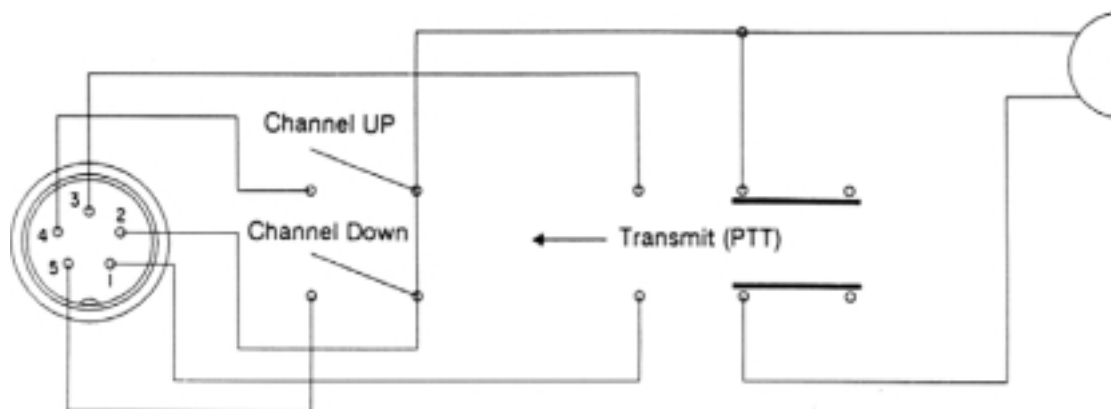

## Microphone Connector

The microphone included with the HR 2510 is a 500 $\Omega$  dynamic microphone, with channel up and down switches. The view of the connector is facing the HR 2510 front panel. The pin connections are as follows:

Pin	Connection
1 & 2	Microphone
3 & 2	PTT Switch
4 & 2	Channel Up Switch
5 & 2	Channel Down Switch
2	Common Ground

# Rear Panel Connectors

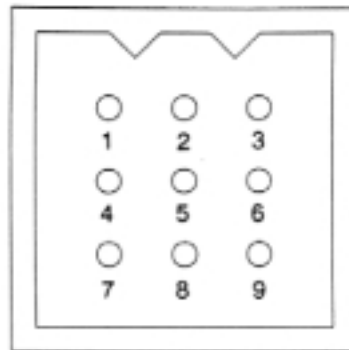

**Accessory Connector**

There are two plugs for the accessory connector included with your HR 2510. One plug contains only a jumper between pins 1 and 7, which is used only to enable the internal speaker. The other plug is wired so that you can conveniently connect accessories to your HR 2510. The view of the connector is facing the rear panel of the unit. The pin connections and wiring color codes are as follows:

Pin	Wire Color	Connection
1 & 2	Red/Black	External Speaker
4 & 5	Blue/Black	PA Speaker
8 & 9	Black/Yellow	CW Key
1 & 7	Red/White	Internal Speaker (Jumper to use internal speaker, open if external speaker is connected.)
3 & 6	n.c.	

## Power Connector



The power cord included with the HR 2510 is color coded. The red wire goes to +13.8V DC nominal and the black wire goes to ground. The HR 2510 is designed for operation with a negative ground system only. The view of the power connector is facing the rear panel of the HR 2510.



## Rear Panel Connectors - continued

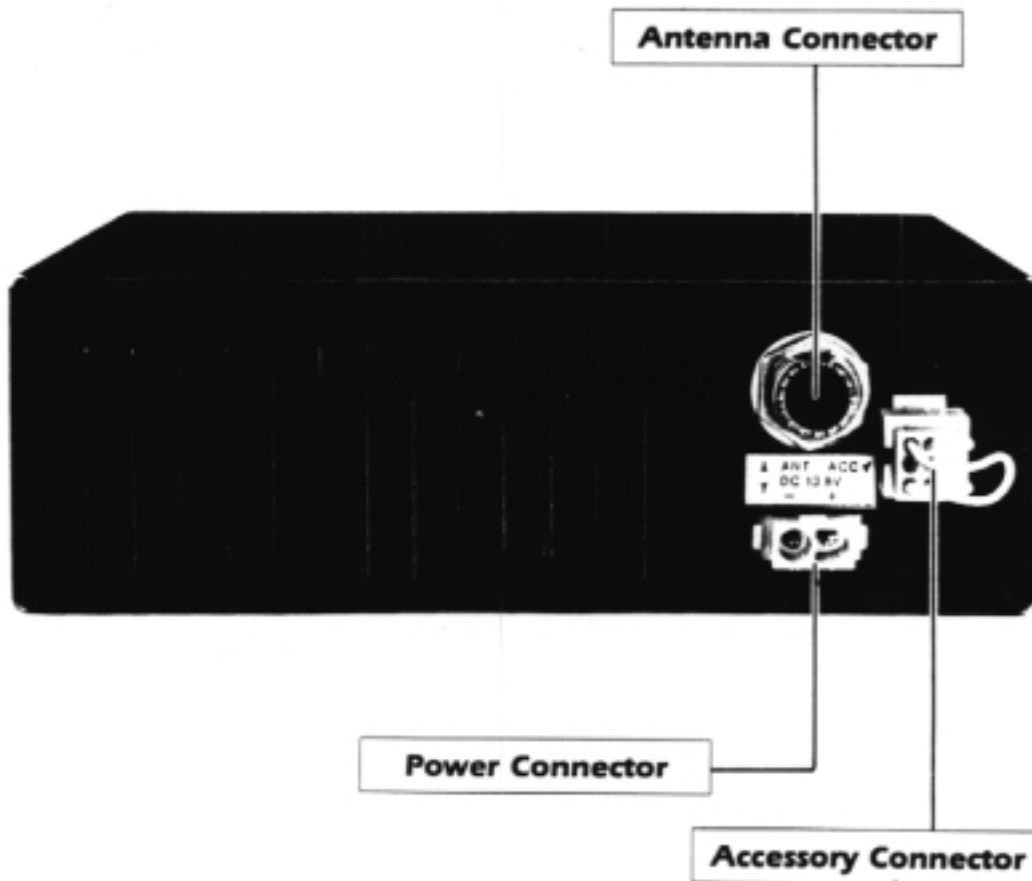

### Antenna Connector

The antenna connects to an ordinary SO-239 Female RF connector on the rear panel. The RF output impedance is 50Ω.

**Warning:** Standing Wave Ratios in excess of 2:1 may cause transmitter damage.

# Installation

## Transceiver Mounting

Plan the location of the transceiver and microphone bracket before starting the installation. Select a location that is convenient for operation and does not interfere with the driver or passenger in the vehicle. The radio should be secured to a solid surface, using the mounting bracket and self-tapping screws supplied.

## Mobile Antenna

The antenna is a very important factor affecting transmission and reception. It is for this reason that we strongly recommend that you install only a quality antenna in your new HR 2510 system. You have purchased a superior quality transceiver; don't diminish its performance by installing an inferior antenna.

Only a properly matched antenna system will allow maximum power transfer from the 50 $\Omega$  transmission line to the radiating element. Your Uniden dealer is qualified to assist you in the selection of the proper antenna to meet your application requirements.

For automobile installations, a quarter wave whip antenna may be used with good effect. The most efficient and practical installation is to mount it on the rear deck or fender top midway between the rear window and bumper.

A short base loaded whip antenna is more convenient to install, but the efficiency is less than a quarter wave whip.

For marine installations, consult your dealer for information regarding an adequate grounding system and prevention of electrolysis.

**Warning:** *Standing Wave Ratios in excess of 2:1 may cause transmitter damage.*

## Ground Information

Most newer U.S. and foreign made cars and small trucks use a 13.8 V DC nominal negative ground system, while some older cars and large trucks use a positive ground system. A negative ground system is generally identified by the negative (–) battery terminal being connected to the vehicle frame or engine block, but if you cannot determine the polarity of your vehicle or are unsure, contact your vehicle dealer for definite information.

**Warning:** *Your HR 2510 is designed for operation on a 13.8 V DC nominal, negative ground system only. Operation on other voltages or polarities may cause fires, transceiver damage, and/or other hazards.*

## Power Cord Connection

The red lead (with the inline fuse) of the supplied power cord is to be connected to a "hot" (positive) wire, and the black lead to ground. As the HR 2510 draws appreciable current during transmitting, you may wish to connect the positive lead directly to the battery, or to a main supply wire.

# Operation

## Selecting a frequency

### VFO Operation

Selecting an operating frequency using the HR 2510's built-in VFO is easy. Make sure that the **F. Lock** key is NOT depressed, and then simply rotate the dial to the desired operating frequency. The VFO will step in either 10 KHz, 1 KHz, or 100 Hz increments. The step increment is indicated by a line under one of the 3 rightmost digits of the frequency display. To change the VFO step, press the **Span** button until the desired step is indicated by the black line. When using the VFO, you do not need to manually select the band segment, as this is done automatically, so that the tuning range is continuous throughout the entire operating frequency range.

### Channel Select Operation

You may also select the operating frequency using the **Channel**  $\wedge$  and  $\vee$  buttons on the front panel or the microphone. The channel select buttons will select any 10 KHz channel in a band segment (50 channels in a; 28.0000 to 28.4900, b; 28.5000 to 28.9900, c; 29.0000 to 29.4900, and 20 channels in d; 29.5000 to 29.6900 MHz). The 10 KHz channel frequencies are pre-programmed and cannot be changed. When stepping up or down, the unit will tune to the nearest 10 KHz channel, NOT to the dial frequency + or - 10 KHz. When you reach channel 50 (channel 20 in segment d), pressing the **Channel**  $\wedge$  button again will step to channel 1, conversely, when you are on channel 1, pressing the **Channel**  $\vee$  button will step to channel 50 (channel 20 in segment d).

To select a band segment, press the **Band** button until the desired band segment letter is displayed. It is displayed on the display above the channel number.

If you press and hold down the **Channel**  $\wedge$  button, the HR 2510 will continuously step up through the pre-programmed channels. As it reaches channel 50, (channel 20 in segment d), it will go to channel 1, stop momentarily, and beep to let you know that you are at channel 1. In the same manner, pressing the **Channel**  $\vee$  key will also do this, but it will stop and beep at channel 50 (channel 20 in segment d) to let you know.

# Operation - continued

## Receive Scanning

The receive scanning functions of your HR 2510 make it easy to find active frequencies. You can scan 50 10 KHz channels in segment a,b, or c, and 20 channels in segment d. Scanning is always from the lower frequency to higher frequencies, and always in 10 KHz steps.

### Scanning Operation

To begin scanning, press the **Scan** button. If there is a transmission on the current frequency (the squelch is broken open), pressing the **Scan** button will just step up one channel. If the squelch is NOT broken, scanning will begin.

The unit will scan through the selected band segment until it encounters a signal strong enough to break (open) the squelch. It will then stop on that frequency for the duration of the transmission. When the transmission stops, the HR 2510 will wait approximately 1.5 seconds before resuming the scan cycle, to allow you to hear a return transmission on that channel. If you take no further action, the scan will resume.

When the scan has stopped for a transmission, momentarily pressing the **Channel**  $\wedge$  or **Channel**  $\vee$  switch on the microphone will stop the scan on the channel.

To exit from scan mode while still scanning, simply press the **Channel**  $\wedge$  or **Channel**  $\vee$  button. If the scan has stopped on an active frequency, you can press the **Channel**  $\wedge$  and  $\vee$  buttons on the microphone, or the **Channel**  $\wedge$  and  $\vee$ , **F. Lock**, **Band**, or **TX** buttons on the front panel of the HR 2510.

## CW Operation

Using CW mode with the HR 2510 is easy. Just select your operating frequency, place the mode switch in CW, and you're ready to transmit CW if you have connected an external key to the accessory plug on the rear of the unit. (See the section on rear panel connectors for information on connecting a CW key.)

To use CW mode with an external key, select an operating frequency, place the mode switch in CW, and you are now ready to operate as semi break-in CW mode. (If you leave the key up for more than 1 second, the receiver is enabled. The HR 2510 has a built-in sidetone oscillator for your convenience. Note: If the TX switch is depressed, the receiver will be disabled. The HR 2510 will NOT transmit in CW mode unless an external key is connected and in a key down condition.

To adjust the pitch of the received CW note, you can use either the VFO or RIT to tune it as desired. (Note: Adjusting the RIT will NOT affect the frequency display)

# Operation - continued

## USB/LSB/AM/FM Operation

Using the HR 2510 for voice communications as either USB, LSB, AM or FM modes is simple. Simply select your desired operating frequency, turn the mode switch to the desired type of operation, and the **PTT** switch controls the transmit and receive. To fine tune the receive signal in USB or LSB, you can use either the VFO or RIT controls. (Note: Using the RIT control to fine tune the receive frequency will NOT affect the frequency display.)

The Mic Gain control can (and should) be used when you are transmitting from a high ambient noise environment. Pressing the **Mic Gain** control reduces the output from the microphone. Press the **Mic Gain** control again to restore it to normal operating condition.

## Noise Blanker

The noise blanker has been designed specifically to remove the interference generated by vehicle ignition systems. To use the noise blanker, simply press the **NB** switch. To disable the noise blanker, just press the **NB** switch again.

## F. Lock

The Frequency Lock function is used to lock the frequency determining controls against accidental changes. To lock the frequency controls, press the **F. Lock** button. To unlock the frequency controls, press **F. Lock** again.

## Beep Control

The Beep control enables and disables a short "beep" tone that is transmitted whenever you release the PTT switch (except in CW mode). This is especially useful when transmitting in USB or LSB mode, as it lets the station that you are working know that you have stopped transmitting. Press the **Beep** button to enable the beep tone, and press it again to disable it.

# Operation - continued

## Multifunction Meter

The Multifunction Meter built in to your HR 2510 provides a number of useful functions. These are:

- S/RF Meter
- MOD Meter
- SWR CAL Meter
- SWR Meter

Every time you press the **Meter** button, the next function will be selected. When you reach the end of the functions, it will start over with the first.

## S/RF Meter

The S/RF meter function provides a visual indication of relative received signal strength and relative transmit power. To use the S/RF function, press the **Meter** button until "RF" is displayed over the meter display. The meter automatically switches function depending on whether you are transmitting (RF Mode) or receiving (S mode). When receiving, the meter reverts to the "S" function.

## MOD Meter

This function gives you an indication of the strength of your modulation when transmitting. There is no function for this meter when receiving signals. To use the MOD function, press the **Meter** button until "MOD" is displayed over the meter display. When receiving, the meter reverts to the "S" function.

## SWR CAL Meter

This mode of the multifunction meter is used to calibrate the meter for the SWR function. To use this mode, first place the unit in CW, AM, or FM modes. Then, press the **Meter** button until the small triangle is visible under the meter near the right side. No other mode indications will be visible at the same time. Press the **PTT** switch on the microphone or hold down the CW key (if connected), and adjust the meter using the SWR CAL control until it indicates up to the triangle. When you have done this, you are ready to check the SWR using the procedure under "SWR Meter". When receiving, the meter reverts to the "S" function.

***Note:** Don't forget that all transmissions must be properly identified, and remember to listen on the frequency before transmitting.*

# Operation - continued

## SWR Meter

After you have calibrated the SWR meter using the SWR CAL function (in the previous section) you are ready to check the SWR of your HR 2510 and antenna system. Press the **Meter** button until "SWR" is displayed above the meter. At this point, pressing the **PTT** switch on the microphone, or holding down the CW key (if connected) to transmit will cause the meter to display the Standing Wave Ratio. When receiving, the meter reverts to the "S" function.

***Note:** If you are in USB or LSB modes and using voice, you will not see a steady SWR indication, since there is no carrier transmitted in these modes. To see a steady SWR indication, you must be in CW, AM, or FM Modes when transmitting.*

***Warning:** Standing Wave Ratios in excess of 2:1 may cause transmitter damage.*

## PA Mode

To use the PA mode of your HR 2510, you must first connect an external PA speaker to the accessory plug on the rear of the unit. (See the section on the accessory plug for more information.) With a PA speaker connected, just pressing the **PA** button will enable the PA mode.

# Specifications

## General

Frequency Range	Band A	28.0000-28.4999 MHz
	Band B	28.5000-28.9999 MHz
	Band C	29.0000-29.4999 MHz
	Band D	29.5000-29.6999 MHz
Microphone	500 $\Omega$ Dynamic, w/PTT and Channel $\wedge$ & $\vee$	
Speaker	8 $\Omega$ , 3W	
Operating Modes	CW, USB, LSB, AM, FM	
Display	Backlit LCD	
Display Items	Frequency, Channel #, Meter, Meter Mode, TX, Band, VFO Span	
Size	7.32" x 10.35" x 2.44"	
Weight	4 lbs 3 oz	

## Transmitter

Frequency Stability	$\pm 300$ Hz Nominal, (@ 25°C, 5 Minutes after Power on)
Output Power	CW 25 W Nominal USB/LSB 25W PEP Nominal AM/FM 10W Nominal
Spurious Harmonic Emissions	-50dB Nominal, all modes
Carrier Suppression	-55 dB Nominal, USB/LSB Modes
Unwanted Sideband Suppression	-45 dB Nominal, USB/LSB Modes
Power Consumption (No Modulation, PTT Depressed)	AM/FM 3A Nominal USB/LSB 0.8A Nominal
Power Consumption (Max Modulation)	CW 5A Nominal (Key Down) AM/FM/USB/LSB 3A Nominal
Microphone Input	1 mV Nominal for 50% AM Modulation
CW Key Voltage/Current	8V DC, 10 mA

## Receiver

Sensitivity for 10 dB S/N	AM .5 $\mu$ V Nominal CW/USB/LSB .25 $\mu$ V Nominal
Sensitivity for 20 dB S/N	FM .5 $\mu$ V Nominal
Adjacent Channel Selectivity	70dB Nominal (10 KHz Spacing)
Max. Audio Output	4W Nominal
RF Gain Range	55 dB Nominal
RIT Range	$\pm 3$ KHz Nominal
"S" Meter Sensitivity @ S9	100 $\mu$ V Nominal
Image Rejection Ratio	65 dB Nominal
Power Consumption, No Signal	500 mA Nominal
Power Consumption, Max Audio	1000 mA Nominal



# Troubleshooting

If your HR 2510 is not performing up to your expectations, please try these simple steps. If you still cannot get satisfactory results after reading this manual and following the troubleshooting steps, please contact your dealer.

Trouble	Check
Unit will not turn on No Power	<ol style="list-style-type: none"><li>1. Check power cord and all connections.</li><li>2. Check power cord fuse.</li><li>3. Check vehicle electrical system.</li><li>4. Check unit grounding.</li></ol>
Poor Reception	<ol style="list-style-type: none"><li>1. Check &amp; adjust squelch.</li><li>2. Check antenna.</li><li>3. Check antenna cable.</li><li>4. Check antenna connectors.</li><li>5. Check operating mode of radio.</li></ol>
Weak Transmission	<ol style="list-style-type: none"><li>1. Check antenna.</li><li>2. Check antenna cable.</li><li>3. Check antenna connectors.</li><li>4. Check operating mode of radio.</li><li>5. Check antenna SWR.</li><li>6. Check antenna grounding.</li><li>7. Check for corrosion on connectors.</li></ol>

# Amateur Radio Operation

Your new President transceiver is designed to be the perfect "first radio" for anyone entering the exciting world of Amateur Radio. From your home, car, or boat, you will find that it opens a door to the world — literally! All you need is a source of electrical power, a suitable antenna, and most important of all, an Amateur Radio Operator's License issued by the Federal Communications Commission (FCC).

You may already have a license. In fact, you may have been a ham operator for many years. But if you don't have a license, you'll find that it's easy to get one, and there is lots of help available. Here are a few tips to help you get started.

First, go ahead and hook up the equipment. Use the receiver section to find out what's going on. *But don't even think of transmitting until you get your license.* That's very important. Transmitting without a license is a violation of Federal Law that could lead to severe penalties. Also, ham operators take the FCC rules very seriously and want nothing to do with "bootleggers" — their term for people who operate without a license.

Second, find out if there's a ham radio club in your area. There are thousands of them across the country, so there's probably at least one in or near your own community. The people at the store where you bought your equipment may be able to tell you. If not, and you don't hear anyone talking about a local club in your area as you tune around the band with your receiver, write to the American Radio Relay League at the address at the end of this section for information on how to contact their local affiliate. Most clubs welcome newcomers, and would be glad to help you obtain your license.

Next, start studying for your license. Don't let the word "study" scare you, because most people can go from knowing absolutely nothing about radio to passing the basic (Novice) class license exam in less than 40 hours of study spread out over several weeks. The test will be on basic radio regulations, a little bit of radio theory, and slow speed Morse Code. Many clubs teach license classes (a fun and easy way to learn about Amateur Radio), and there are good books, cassette tapes, computer programs, and lots of other study aids available. The ARRL publishes a book, *Tune in the World with Ham Radio* which is usually packaged with two tape cassettes and has all you need to know. But, don't overlook the products of commercial publishers that you will see in radio and electronics stores.

Finally, you'll be ready to pass the exam. You won't have to go to an imposing Federal office building in a big city to take the test, because these days, the FCC has ham volunteers give all of the exams. For the Novice license, the examiners can be any two hams with General or higher class licenses who are at least 18 years old and not related to you. And, the Novice exam is free!

The Novice class license will let you use your HR 2510 between 28.1 and 28.5 MHz — on CW (Morse Code) between 28.1 and 28.5 MHz, and on SSB (voice) between 28.3 and 28.5 MHz. Your HR 2510 has more frequencies and operating modes built in, which you will be able to use once you have a General or higher class license. There's no rush — your Novice license will be good for ten years, and even then you can renew it indefinitely.